

Access Control & Security Management Solutions



a strong foundation

visionary

Our Company

Our Culture – Your Foundation

Some companies build products. At Hirsch, we build a culture.

We believe the ideal culture will produce the best services and support infrastructure. Our goal is to make your investment in an access control or security management system safe and secure – today and tomorrow.

We have a culture that listens. We have a culture that is committed to the satisfied customer. Incidentally, this approach also produces the best products. With Hirsch, you are not just buying a product – you are buying a long term relationship.



The Hirsch Solutions Room enables prospective customers to see their specific products and applications in operation before they buy.



The Sales Support Team is available product selection, pricing, ordering

Here for You

We have a worldwide network of authorized dealers to provide local expertise in needs assessment, system design, installation, commissioning, and ongoing service. This group is backed up by the Hirsch Technical Support Team which is available to answer application questions and assist in troubleshooting field problems. At each desk is an array of hardware components that can be quickly configured to replicate the customer's configuration.

The Hirsch Learning Center provides continuous training programs for installation, commissioning, operation and administration on all our systems. Students receive a hands-on classroom learning experience, using dedicated PCs, controllers, and field hardware. Our instructors are professionals in adult education and instructional design.

Quality Processes

Software may be the window into the system, but the hardware is the foundation. So it gets special attention.

We have decades-proven processes to ensure the reliability of our systems. After fabrication, circuit boards and firmware are life-cycled and burned in for a week. Then, we factory assemble all the components and test the entire unit for proper operation before shipping. This results in an MTBF of 100 years for our controllers. Even though Hirsch uses "just in time" manufacturing processes, we typically maintain ample inventory for prompt shipments from stock.

Our Velocity software is designed from the bottom up around the firmware in our controllers and is extensively tested in factory and field settings to ensure performance, reliability, and system integrity. We design forward-compatibility into our systems so our customers will find expansion and modernization to be simple and economical.



to provide timely answers to questions concerning and shipments.



Each Technical Support representative has a variety of equipment that can be configured to match the customer's environment, so callers get relevant, timely and accurate answers.



ABOVE – Results-oriented instructors ensure our dealers can install and troubleshoot our systems and our end-users can operate and administer their system.

RIGHT – The Hirsch Learning Center trains nearly a thousand dealers and end-users each year using state of the art facilities and equipment with a hands-on approach.



Products & Technologies

Founded with Vision

We were founded in 1981 to bring to market the first secure keypad. Our idea was to "scramble" the digits on a telephone-like keypad so they came up in a different position every time. The resulting product became the ScramblePad®, for which we were granted a patent. The ScramblePad was quickly embraced by government intelligence agencies for its high security features.



The Innovation Continues

After the ScramblePad, we pioneered a line of controllers renowned for their reliability and security features. And we added support for other secure reader technologies such as biometrics and smart cards. Then we created encrypted networks to connect the controllers to PC workstations. Client/Server architectures followed as Hirsch led the industry in enterprise-class configurations which reside on the corporate LAN/WAN. We built our system from

the bottom up. It's built on our hardware, our firmware, and our software. We build in integrity, as well.

A Long Term Investment

Our hardware is proven for its reliability, flexibility and long life cycle. Our software excels in ease of install, ease of use, and broad feature set. It wins industry awards to prove it. For most applications, a Hirsch system solution results in the lowest total installed cost, as well as the lowest life cycle cost.

Standards for Security

We embrace industry and de facto standards. Our products are designed for and obtain Underwriters Laboratories Listings and Approvals for UL 294 Access Control Systems and UL 1076 Proprietary Burglar Alarm Systems. Software development focuses on the latest Microsoft operating systems and databases.



The Hirsch product line is as solid as it looks—a



After assembly, testing is conducted by a skilled technician to ensure each unit meets or exceeds Hirsch's high quality control standards.



LEFT - Security Industry Association Awards for Access Control & Integrated Systems

CENTER - American Electronics Association Award for Enterprise Class Systems

RIGHT - Moscow International Protection & Security for Best Product



award-winning, high security, easy to install and use, and most important of all, reliable.

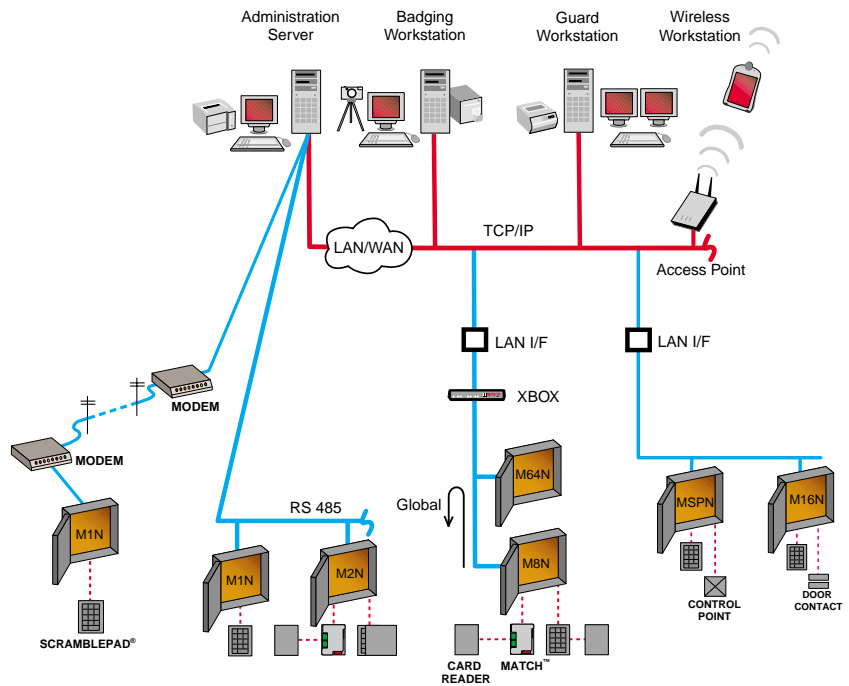

Modular architectures allow you to start small and expand to the enterprise.

Hirsch's on-site warehouse prides itself on meeting shipment commitments, including rush orders.

Our Customers

A Rich Variety

Our systems can start small and expand to serve the enterprise, worldwide. So, it is no surprise that our customer base includes a rich variety of applications, building types and industries. Through the years we have continuously added to the application library in our controller firmware to accommodate the unique needs of those we serve. We have a strong base of customers in the following industries:

- Federal Governments, Embassies
- State, Provincial & Local Governments
- Military & Defense
- Corporate & Regional Headquarters
- High Tech Manufacturing
- Banking & Finance
- Vaults
- Hospital & Health Care
- Educational Facilities
- Correctional Facilities
- Utility Plants
- Retail
- Multi-Site Enterprises
- Multi-Tenant Office Buildings
- Laboratories

Relationship Programs

Hirsch serves the USA and Canada with a team of Region Managers located throughout North America. These professionals have the technical background, industry knowledge, and product expertise to assist the dealer installer and end user in the selection and application of Hirsch system solutions to meet their access control and security management needs. The Region Manager is committed to customer satisfaction and is the factory liaison for all business in their territory.

An inside sales team based at our headquarters coordinates with our Region Managers to support our customers for inquiries regarding system configuration, product availability, pricing, literature requests, order entry, and Return Materials Authorizations.

A separate dedicated sales team serves our customers in Latin America, Asia/Pacific, and Europe/Middle East/Africa.

Federal government agencies have always been an important market to Hirsch. A marketing program group serves them directly and worldwide. A government liaison office is maintained in suburban Washington, D.C., and Hirsch has a GSA contract

(GS-07F-7733C) to simplify procurement by state and federal agencies.

Corporate account programs are available to our customers with multiple sites, volume purchase commitments, and special support requirements.

Systems with Integrity

Our customers are a testament to the reliability of our systems and the integrity of our company. Get to know us. You will see how we have built a strong foundation around a culture. We have a vision for a new kind of business relationship.

Relationships outlast technology. We are innovators for both.

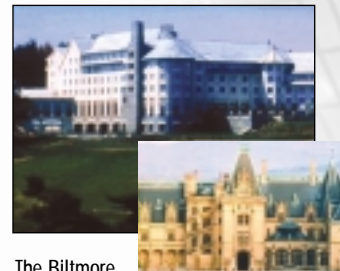

The Billmore House and Inn, Asheville, NC



People's Bank Headquarters Building, Bank of China, Beijing, China



Nordstrom, South Coast Plaza,
Costa Mesa, CA



Valley Com Regional 9-1-1
Dispatch Center, Kent, WA



MEPhI-Moscow Engineering Physics
Institute (State University), Russia



Iowa State University, Ames, IA



Wells Fargo Bank,
San Francisco, CA



Saint Agnes Medical Center, Fresno, CA



Westchester Medical Center,
Westchester, NY



Dwight D. Eisenhower Executive Office
Building, Washington, D.C.

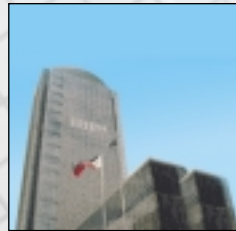

Ayala Tower and Manila Stock
Exchange, Manila, Philippines



Canadian Coast Guard Academy,
Westmont, Nova Scotia, Canada

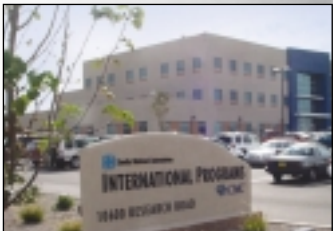

Sandia National Laboratories,
Albuquerque, NM



Sacramento International Airport,
Sacramento, CA



Department of Energy,
Washington, D.C.



City Hall, Sacramento, CA

Our Mission

It is our responsibility to understand our customers' challenges in providing a safe and secure environment for their employees, customers and visitors; in protecting their property and assets—and to assist them with solutions.

We nurture a unique culture that begins with a commitment to integrity, extends to the pursuit of quality, and passionately focuses on the customer. Our employees, with whom we embrace continuous improvement, drive our culture.

We manufacture access control and security management solutions that are consistent, powerful, secure and flexible. Above all, our products shall be reliable.

We serve government, commercial, industrial, and institutional customers worldwide.

We strive to be the best business partner to our customers and the distribution channels that assist us in serving them.

We will build on our reputation for high security and reliability and be the premium offering in our industry.



Global Headquarters, Santa Ana, CA

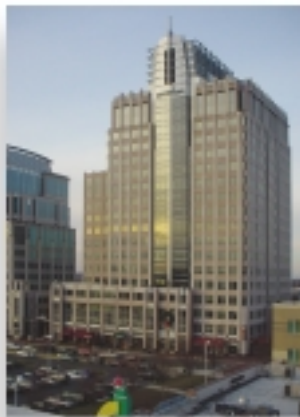

Hirsch Government Liaison Office,
Reston, VA (Suburban Washington, D.C.)



Global Headquarters
1900 Carnegie Ave., Bldg. B
Santa Ana, CA 92705 USA
949-250-8888 Fax 949-250-7372
www.HirschElectronics.com

CP002-203